

# The “PWM Switch” concept included in mode transitioning SPICE models.

Christophe BASSO - ON Semiconductor  
 14, rue Paul Mesplé - BP1112 - 31035 TOULOUSE  
 Cedex 1 – France - 33 (0)5 34 61 11 54  
 e-mail: christophe.basso@onsemi.com,

## Introduction

Vatché Vorpérian, from the Jet Propulsory Laboratory (Pasadena, CA), introduced his PWM Switch concept in the 90's. At that time, he derived an invariant three-terminal model that could be inserted in any converter featuring a power switch and a diode. Thanks to his approach, solving ac transfer functions of complex converters became easier, compared to the former State-Space Averaging technique (SSA). Based on his original work dedicated to current-mode control (CM) and voltage-mode control (VM), several SPICE models have been constructed. In the VM domain, for instance, Vorpérian adopted two different configurations to derive his Continuous Conduction Mode (CCM) and Discontinuous Conduction Mode (DCM) models. SPICE subcircuits built on these two different models, were forced to use mode switches that complicated the implementation and seriously hampered the converge friendliness. Also, in current-mode control, Vorpérian never published the DCM case. This paper will first quickly introduce the PWM Switch model to further derive two novel simple auto-toggling VM and CM models.

## The PWM Switch model

The concept of the PWM Switch model can actually be compared to the Ebers-Moll work, a small-signal representation of bipolar transistors. The idea was simple: in a transistor arrangement, replace the transistor symbols by their small-signal models to turn the whole circuits into a fully linear circuit. As a result, traditional mess/node analysis could be carried over the circuit to reveal the transfer functions of interest.

The PWM Switch model does not differ from this idea. Figure 1 represents a classical buck converter:

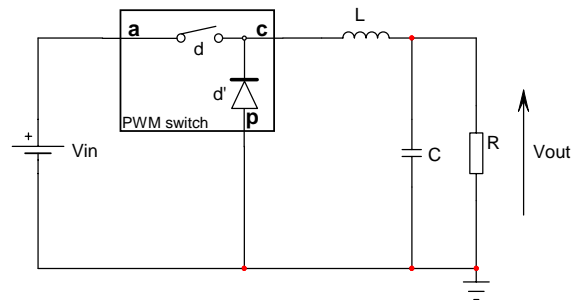

Figure 1 – a buck converter showing the position of the switch and the diode

The model terminals are named “a”, like active, “p” for passive, and finally “c” for common, where both switch and diode terminals join. As reference [1] details, it is possible to place this particular configuration, a three-terminal model, in any switching converter operating a couple transistor + diode. The relationship between the waveforms, e.g. between  $V_{ac}$  and  $V_{cp}$ , will always remain the same: this is the principle of invariance!

To derive such a model, the technique consists of observing the waveforms pertinent to a given configuration and average them over a switching period. The adopted configuration for the CCM mode is the buck type of arrangement, also called the “common passive” option. Yes, like the common emitter for bipolars... Let us draw the waveforms depicting figure 1 operation. They appear on figure 2a for the terminal currents, and on figure 2b of the voltages:

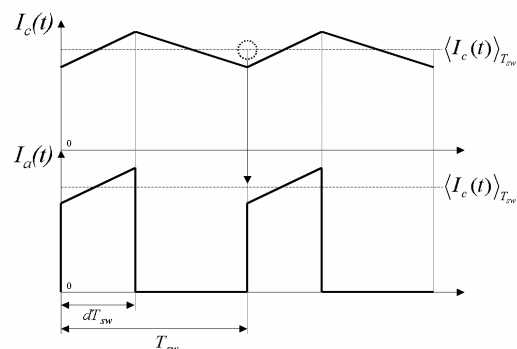

Figure 2a – terminal currents in CCM

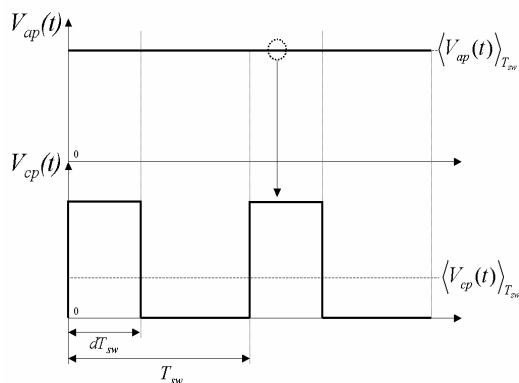

Figure 2b – terminal voltages in CCM

If we average these waveforms, we obtain:

$$\langle I_a(t) \rangle_{T_{sw}} = I_a = \frac{1}{T_{sw}} \int_0^{T_{sw}} I_a(t) dt = d \langle I_c(t) \rangle_{T_{sw}} = d I_c$$

eq.1, for the current relationship.

$$\langle V_{cp}(t) \rangle_{T_{sw}} = V_{cp} = \frac{1}{T_{sw}} \int_0^{T_{sw}} V_{cp}(t) dt = d \langle V_{ap}(t) \rangle_{T_{sw}} = d V_{ap}$$

eq. 2, for the voltage relationship.

If we take a closer look at equations 1 and 2, we see an “input” current  $I_a$  equal to an “output” current  $I_c$  multiplied by a ratio  $d$ , the duty-cycle. For the terminal voltages, the “output” voltage  $V_{cp}$  equals the “input” voltage  $V_{ac}$ , again multiplied by  $d$ . Yes, of course, it looks like a transformer featuring a ratio of  $d$ ! This is what figure 3 shows:

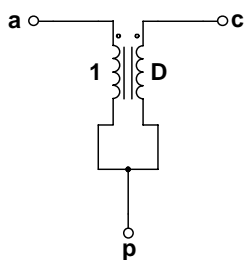

Figure 3 – the large-signal representation of the PWM Switch model in VM-CCM...

This is the large-signal representation of the couple transistor + diode as you can find them in a flyback, buck-boost and so on operated in CCM - VM. To use this model,

simply remove the diode and the power switch, then install the model respecting the polarity. The model, once translated in SPICE uses a few code lines (IsSpice syntax):

```
.SUBCKT PWMCCMVM a c p dc
*
* This subckt is a voltage-mode CCM model
*
BVcp 6 p V=V(dc)*V(a,p)
Blap a p I=V(dc)*I(VM)
VM 6 c
.ENDS
```

Figure 4 portrays this CCM model working in a boost circuit:

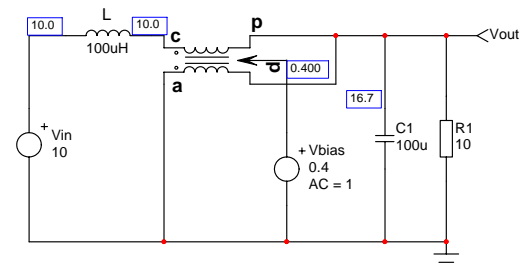
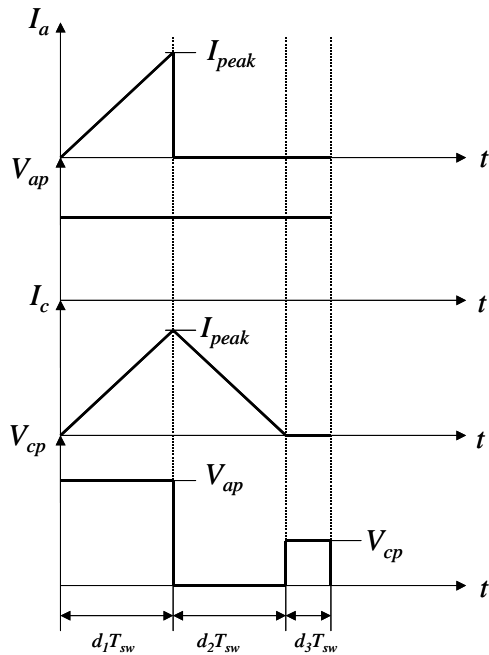

Figure 4 – a boost circuit featuring the non-linear CCM PWM switch model

The dc points confirms the static transfer function of a boost,  $M = \frac{1}{1-d}$ , which equals 1.666 V. Once multiplied by  $V_{in} = 10$  V, we obtain the right bias point. The complete linearization of this model is thoroughly covered in [1].

### The DCM case

In the second part of his paper dealing with the DCM case, Vorpérian departed from the original “common passive” arrangement to study a “common-common” configuration. Naturally leading to a different model arrangement, it was particularly difficult to develop an auto-toggling DCM-CCM SPICE model without adding various signal routing switches. Keeping the original arrangement, let us derive the non-linear DCM model. The technique remains the same: identify the waveforms and average them over a switching cycle. This is what figure 5 illustrates. A third interval now appears, when the inductor current is null: this is the dead time (DT).



**Figure 5** – the DCM waveforms of the PWM model in the “common passive” configuration.

Based on figure 5, dealing with triangles makes averaging an easy exercise:

$$I_a = \frac{I_{peak} d_1}{2} \quad \text{eq. 3}$$

Now, the average value of  $I_c$  is found by summing up the half-triangles areas, since the DT area ( $d_3 T_{sw}$ ) is null:

$$I_c = \frac{I_{peak} (d_1 + d_2)}{2} \quad \text{eq. 4}$$

From eq. 3, we can derive  $I_{peak}$ :

$$I_{peak} = \frac{2I_a}{d_1} \quad \text{eq. 5}$$

and plug it in equation 4. We obtain the relationship between  $I_a$  and  $I_c$ :

$$I_c = I_a \frac{(d_1 + d_2)}{d_1} \quad \text{eq. 6}$$

In equation 6, the difference between CCM (eq. 1) and DCM lies in the presence of  $d_3 T_{sw}$ , the dead time. When this

term vanishes to zero, the PWM switch enters CCM. In equation 6, if  $d_2 = 1 - d_1$ , or  $d_3 T_{sw} = 0$ , it simplifies to  $I_a = I_c d_1$  which is equation 1.

We can now average the  $V_{cp}$  waveform, seeing that the  $d_3 T_{sw}$  period offers a high impedance state, letting  $V_{cp}$  freely appearing across the  $p$  and  $c$  terminals:

$$d_3 = 1 - d_1 - d_2 \quad \text{eq. 7}$$

$$V_{cp} = V_{ap} d_1 + V_{cp} (1 - d_1 - d_2) \quad \text{eq. 8}$$

$$V_{cp} - V_{cp} (1 - d_1 - d_2) = V_{ap} d_1 \quad \text{eq. 9}$$

$$V_{cp} = V_{ap} \frac{d_1}{(d_1 + d_2)} \quad \text{eq. 10}$$

Again, this equation simplifies to  $V_{cp} = V_{ap} d_1$  when  $d_2 = 1 - d_1$ . The equation becomes the CCM one... (see equation 2)

If we look back at equations 6 and 10, we again have a simple transformer whose turn-ratio now depends upon

$\frac{d_1}{(d_1 + d_2)}$ . **Figure 6** shows the new configuration for the DCM switch model:

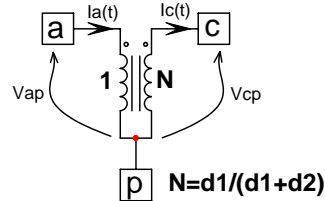

**Figure 6** – a simple dc transformer affected by a

$\frac{d_1}{(d_1 + d_2)}$  ratio...

### Deriving $d_2$

If the controller imposes  $d_1$ ,  $d_2$  needs to be computed as its value depends on the demagnetization time, hence current and inductance value.  $d_2$  can be derived observing figure 5, using the buck configuration. A second equation for the peak current definition can be derived as the switch closes during the *on* time:

$$V_{ac} = L \frac{I_{peak}}{d_1 T_{sw}} \quad \text{eq. 11}$$

From equation 4, we can see that:

$$I_{peak} = \frac{2I_c}{(d_1 + d_2)} \quad \text{eq. 12}$$

Extracting  $I_{peak}$  from equation 11 and equaling it to equation 12 leads to:

$$\frac{2I_c}{(d_1 + d_2)} = \frac{V_{ac} d_1 T_{sw}}{L} \quad \text{eq. 13}$$

Solving for  $d_2$  gives us the final equation we are looking for:

$$d_2 = \frac{2LF_{sw}}{d_1} \frac{I_c}{V_{ac}} - d_1 \quad \text{eq. 14}$$

We are all set! We know that both funding equations 6 and 10 naturally toggle from DCM to CCM when  $d_2$  equals  $1 - d_1$ . Thus, we simply need to clamp our  $d_2$  generator between 0 and  $1 - d_1$ . The final model can be downloaded from reference [4] link.

### Testing the model

A simple test consist of comparing a closed-loop transient response between a cycle-by-cycle buck converter and its equivalent using the new auto-toggling PWM switch mode. Figure 7a shows how to wire this model and figure 7b portrays the switching results compared to the averaged results. Please note that the converter experiences a fast light load to full load transition, thus crossing from DCM to CCM. Looking at figure 7b makes it difficult to see which is which... This confirms the validity of the approach.

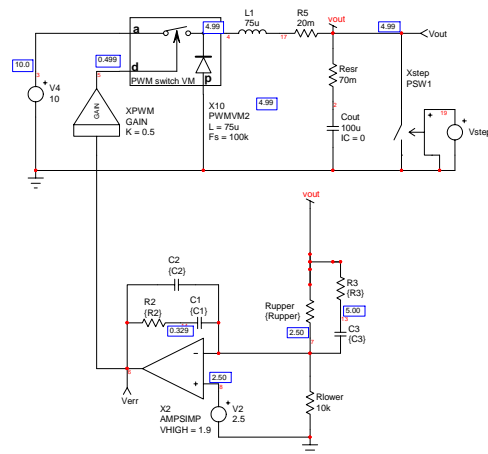

Figure 7a – the closed-loop averaged model

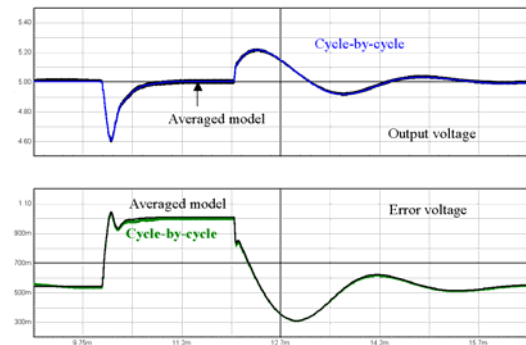

Figure 7b – difficult to distinguish between both models

### Current-mode control

The PWM switch operating in current control (CC) was described in reference [3]. However, Vatché Vorpérian solely published his work on the CCM case but never on the DCM.

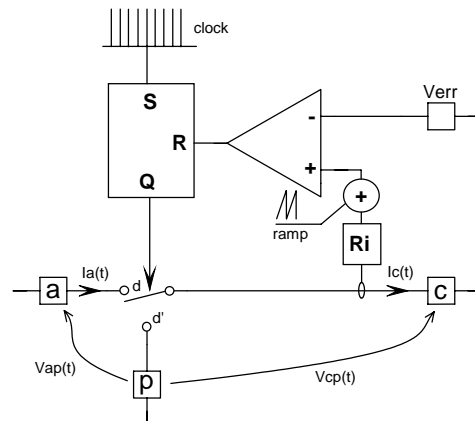

Figure 8 – the CC-PWM switch architecture

Figure 8 shows the CC-PWM switch arrangement where the final peak current is actually the setpoint imposed by the error voltage  $\frac{V_{err}}{R_i}$ , minus a term imposed by the stabilization ramp. Figure 9 depicts a slope graph referring to the DCM case.

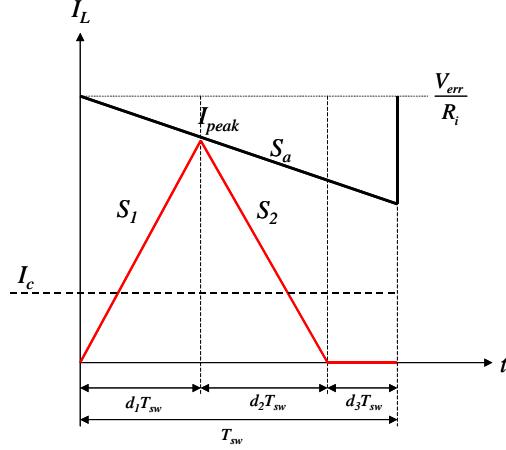

Figure 9 – the DCM slope graph

As we did for the voltage-mode case, we need to find a relationship which offers an analytical description of  $I_c$ . If we start from  $t = 0$ , we have  $V_{err}$ , trying to impose a peak current setpoint of  $\frac{V_{err}}{R_i}$ .

However, the external ramp compensation  $S_a$  (in V/s) diminishes this setpoint by subtracting from  $V_{err}$ . Therefore, the real peak current  $I_{peak}$  is :

$$I_{peak} = \frac{V_{err} - d_1 T_{sw} S_a}{R_i} \quad \text{eq. 15}$$

From this point  $I_{peak}$ , we can reach  $I_c$  via the off slope  $S_2$ , expressed in A/s:

$$I_c = \frac{V_{err} - d_1 T_{sw} S_a}{R_i} - \alpha d_2 T_{sw} S_2 \quad \text{eq. 16}$$

where  $\alpha = 1 - \frac{d_1 + d_2}{2}$ . Re-arranging equation 16 gives:

$$I_c = \frac{V_{err}}{R_i} - \frac{d_1 T_{sw} S_a}{R_i} - d_2 T_{sw} \frac{V_{cp}}{L} \left(1 - \frac{d_1 + d_2}{2}\right) \quad \text{eq. 17}$$

To better stick to the CCM current-mode PWM switch model original definition, we can re-write equation 17 :

$$I_c = \frac{V_{err}}{R_i} - I_\mu \quad \text{eq. 18}$$

where  $I_\mu$  is simply :

$$I_\mu = \frac{d_1 T_{sw} S_a}{R_i} + d_2 T_{sw} \frac{V_{cp}}{L} \left(1 - \frac{d_1 + d_2}{2}\right) \quad \text{eq. 19}$$

Please note that this equation simplifies to the original CCM equation when  $d_2 = 1 - d_1$ . This is a natural CCM-DCM toggling effect!

### Deriving the duty-cycles $d_1$ and $d_2$

Thanks to figure 5 waveforms, we can work out the rest of the needed equations. From the DCM voltage-mode model we know:

$$V_{cp} = V_{ap} \frac{d_1}{(d_1 + d_2)} \quad \text{eq. 20}$$

or:

$$\frac{V_{cp}}{V_{ap}} (d_1 + d_2) = d_1 \quad \text{eq. 21}$$

Again, this equation simplifies to

$\frac{V_{cp}}{V_{ap}} = d_1$  when  $d_2 = 1 - d_1$ . This is the CCM equation...Solving equation 21 for  $d_1$  gives:

$$d_1 = \frac{d_2 V_{cp}}{V_{ap} - V_{cp}} \quad \text{eq. 22}$$

From figure 5, we can again write a few basic equations:

$$I_a = \frac{I_{peak} d_1}{2} \quad \text{eq. 23}$$

Finally, it can be shown that  $I_a$  and  $I_c$  are linked by:

$$I_a = I_c \frac{d_1}{d_1 + d_2} \quad \text{eq. 24}$$

Again, this equation simplifies to  $I_a = I_c d_1$  when  $d_2 = 1 - d_1$ . This is the original CCM equation. Further to a little more efforts, the duty-cycle  $d_2$  can be computed by:

$$d_2 = \frac{2LF_{sw}}{d_1} \frac{I_c}{V_{ac}} - d_1 \quad \text{eq. 25}$$

The final model appears on figure 10 and corresponds to the same architecture of that of the CCM model described in [3].

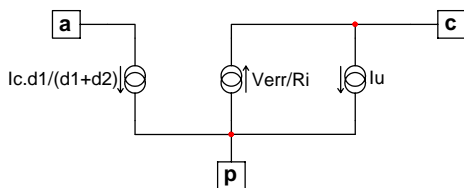

Figure 10 – the DCM current-mode model

### Testing the model

As we did for the voltage-mode case, we can bang the output of a cycle-by-cycle buck converter operated in a discontinuous current-mode control and compare it to the answer delivered by the new auto-toggling averaged model. Figure 11 shows the averaged buck version and figure 12 displays the two results.

### Conclusion

This paper has shown how by reformulating some of the equations of the PWM Switch model, two new auto-toggling SPICE subcircuits operating in voltage-mode or current-mode were derived. Various test circuits have demonstrated a) the validity of the approach b) their convergence robustness c) their ability to

quickly fit in any known structures (SEPIC, CUK...)

Two versions of these VM and CM models exist: one using INTUSOFT's IsSpice and one based on CADENCE's PSpice. They both can be sent upon request to the author or via [4].

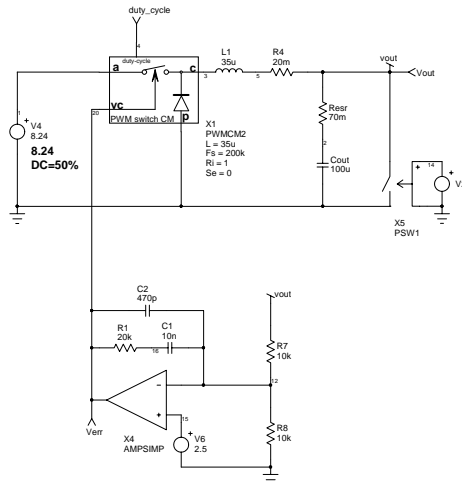

Figure 11 – the new averaged current-mode model

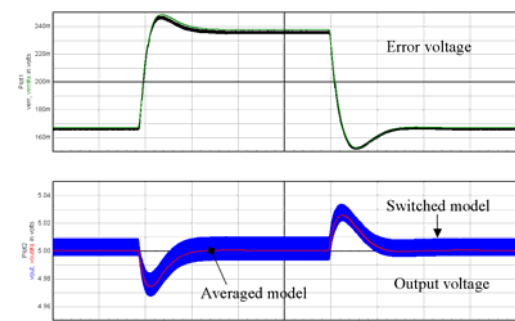

Figure 12 – simulation results comparing a DCM current-mode control buck output response versus the output delivered by the new auto-toggling current-mode model.

### References

1. R. B. Ridley, "A new small-signal model for current-mode control", PhD. dissertation, Virginia Polytechnic Institute and State University, 1990
2. Vatché Vorpérian, "Simplified Analysis of PWM Converters Using The Model of The PWM Switch, Parts I (CCM) and II (DCM)", Transactions on Aerospace and Electronics Systems, Vol. 26, N°3, May 1990.
3. Vatché Vorpérian, "Analysis of Current-Controlled PWM Converters using the model of the Current-Controlled PWM Switch", Power Conversion and Intelligent Motion Conference, 1990, pp. 183-195.
4. <http://perso.wanadoo.fr/cbasso/Spice.htm>